

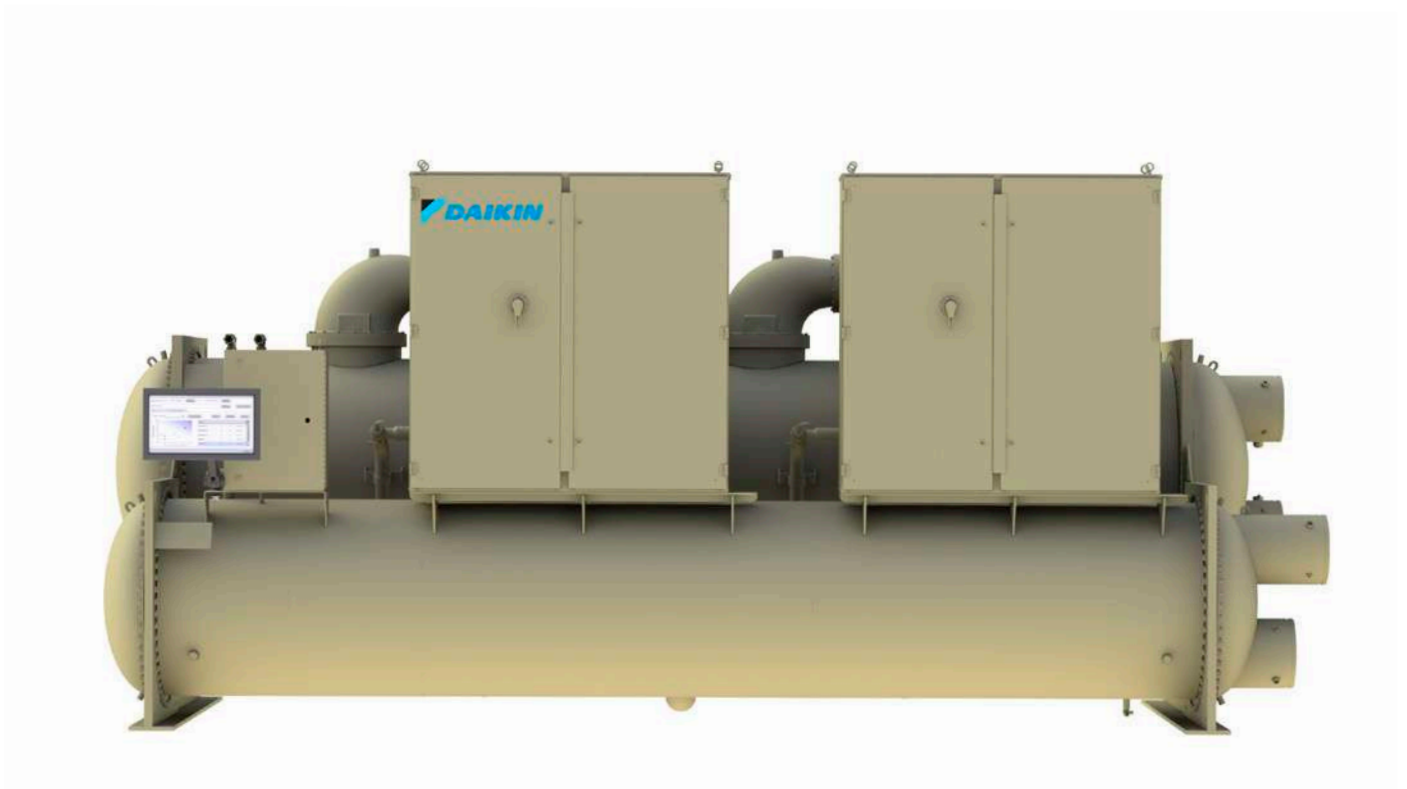

Catalog 632-4

## Magnitude® Magnetic Bearing Centrifugal Chillers

Model WME, C-vintage  
400 to 1600 Tons (1400 to 5600 kW)  
R-134a or R-513A Refrigerant



<b>Introduction</b> .....	<b>3</b>	Optimizing Efficiency .....	12
Technology That Just Makes Sense .....	3	Evaporator .....	13
Features and Benefits Summary .....	3	Condenser .....	13
<b>Features and Benefits</b> .....	<b>4</b>	Retrofit Knockdown .....	15
The Compressor Technology .....	4	<b>Engineering Guide Specifications</b> .....	<b>17</b>
Integrated Variable Frequency Drive .....	5	Magnitude® Magnetic Bearing Centrifugal Chillers ..	17
The Control Technology .....	5		
Certifications and Standards .....	6		
Factory Testing .....	6		
<b>Dimensions</b> .....	<b>7</b>		
Unit Dimensions .....	7		
Drawing Notes .....	8		
<b>Options and Accessories</b> .....	<b>9</b>		
Unit Options .....	9		
Vessel Options .....	9		
Controls Options .....	9		
Electrical Options .....	10		
Special Order Options .....	10		
<b>Refrigeration Diagram</b> .....	<b>11</b>		
<b>Application Considerations</b> .....	<b>12</b>		
Location Requirements .....	12		
Vibration Mounting .....	12		
System Design .....	12		

**Manufactured in an ISO 9001 & ISO 14001 certified facility**





## Magnitude® Magnetic Bearing Chillers

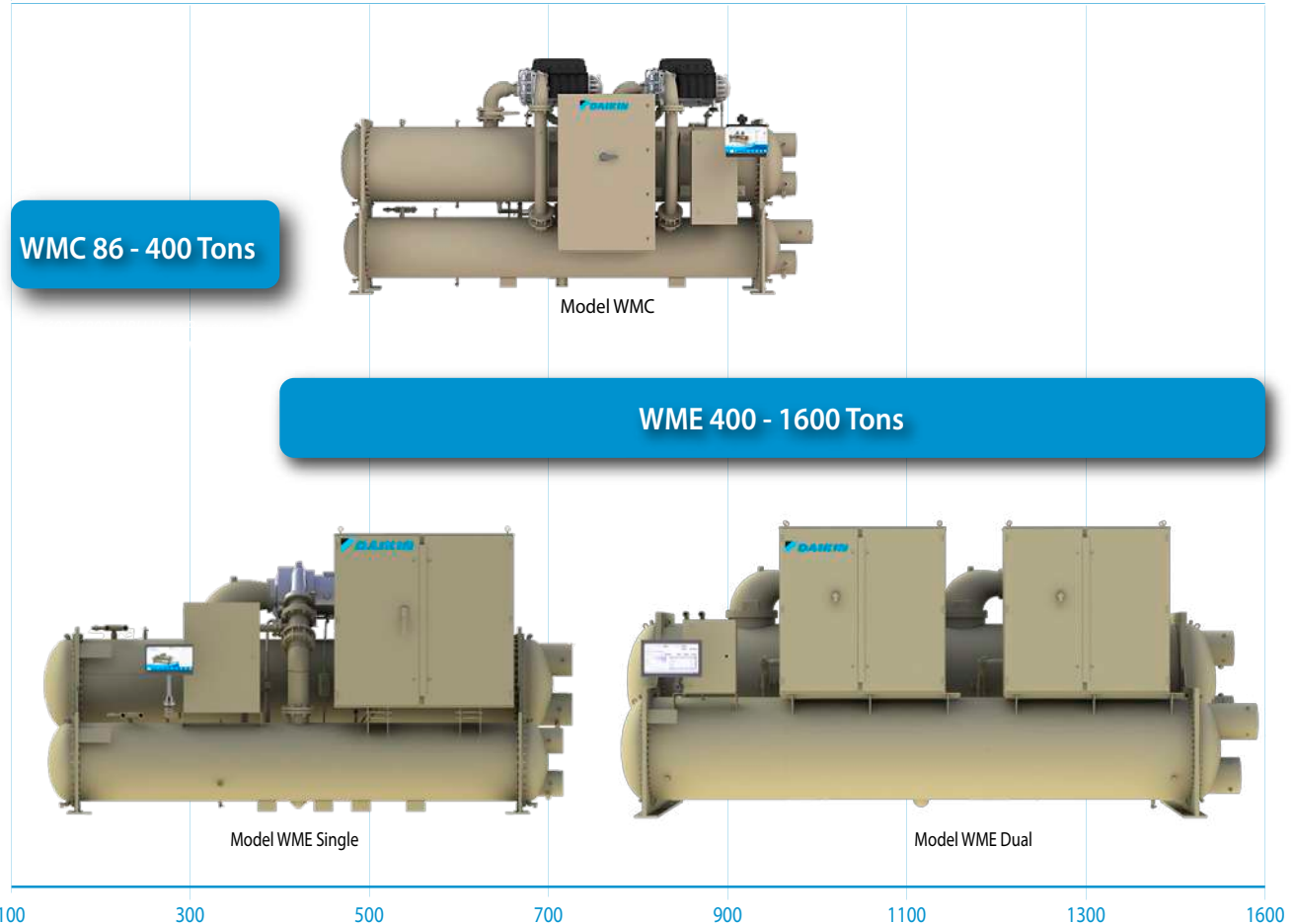

### Technology That Just Makes Sense

The industry's next generation of centrifugal chillers is here today with Daikin Magnitude® chillers. This technology incorporates centrifugal compressors utilizing integral variable frequency drives with oil-free operation thanks to magnetic bearings. Direct-drive technology and high efficiency compressor(s) are used in conjunction with highly efficient heat exchangers, as well as other important features including:

- State-of-the-art magnetic bearing compressor with oil-free technology
- Unit-mounted Variable Frequency Drive
- Positive pressure design
- Hermetic, permanent magnet, direct-drive motor
- User-friendly MicroTech® controls
- Open Choices™ controls feature for BAS flexibility
- R-134a or R-513A refrigerant
- AHRI certification

### Features and Benefits Summary

#### The Compressor Technology

- Magnetic bearing system that results in greater efficiency and reliability, more sustainable performance, reduced operating and maintenance costs, and low vibration and sound levels compared to traditional oil centrifugals.

#### Integrated Variable Frequency Drive (VFD)

- Unit-mounted VFD modulates compressor speed to obtain optimum efficiency at all load and lift conditions.

#### The Control Technology

- Onboard digital electronics provide smart controls and include a regenerative power system, user-friendly operator interface, RapidRestore® and RideThrough® options, and Open Choices™ BAS flexibility.

#### Certifications and Standards

- Meets ASHRAE Std. 90.1, AHRI 550/590, and IBC/OSHPD Seismic, and contributes to LEED® credits. Daikin has achieved a UL Environmental Product Declaration (EPD) certification.

#### Factory Testing

- Ensures trouble free startup and reliable operation.

## The Compressor Technology

Model WME's exceptional efficiency and reliability is due to its cutting-edge permanent magnet motor and magnetic bearing compressor technology. A digitally-controlled magnetic bearing system replaces conventional oil lubricated bearings and a direct drive motor eliminates the need for a lubricated gear box. The compressor shaft, shown in Figure

1, levitates on a magnetic cushion and is the compressor's only major moving component. Sensors at each magnetic bearing provide real-time feedback to the bearing control system. As a result of this sophisticated design, model WME has many advantages over chillers with traditional centrifugal compressors.

**Figure 1: Magnetic Bearing Compressor Shaft**

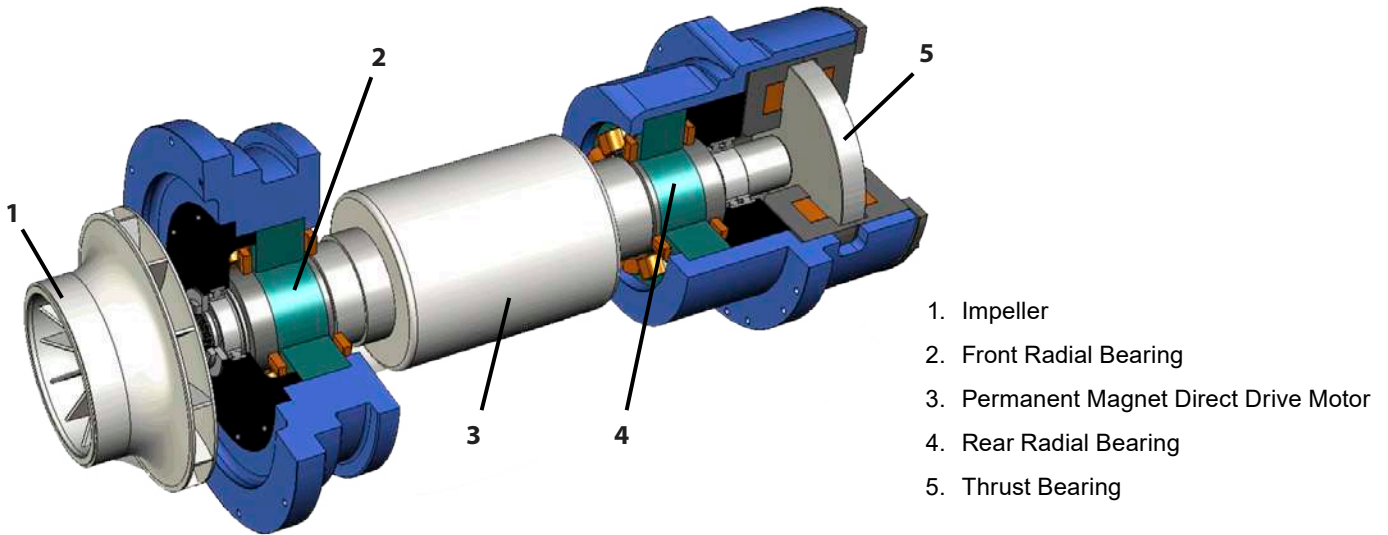

- 1. Impeller
- 2. Front Radial Bearing
- 3. Permanent Magnet Direct Drive Motor
- 4. Rear Radial Bearing
- 5. Thrust Bearing

### **Oil-Free Compressor Design Benefits**

***No Oil Management System = Greater Reliability***

With magnetic bearings operating in a magnetic field instead of oil-lubricated bearings, the oil handling equipment is removed. No need for:

- oil pumps
- oil reservoirs
- oil coolers
- oil filters
- water regulating valves
- oil relief valves
- oil storage and disposal
- oil system controls, starter, piping, heaters, etc.

that are needed to maintain oil quality. These devices can be a fault source in traditional chillers, and removing them significantly increases unit and system reliability.

***No Oil System = Reduced Maintenance Costs***

With oil removed from the system, oil samples, oil changes, oil system maintenance, oil filter changes, and leaks are eliminated.

***Totally Oil-Free Operation = Greater Efficiency***

The use of oil-free magnetic bearing technology significantly increases chiller efficiency by reducing frictional losses within the bearing system.

In addition, efficiency improvements can be realized since there is no oil to coat the heat transfer surfaces.

***No Oil Loss = Sustainable Performance***

With no possibility of oil loss at light loads or due to worn seals, the original energy saving efficiency can be maintained for the life of the chiller.

***No Oil System = Low Vibration & Sound Levels***

With the use of magnetic bearings, the compressor vibration levels are extremely low, minimizing vibration that could be transmitted to the structure.

With low vibration levels, sound levels are lower compared to traditional centrifugal chillers.

## Integrated Variable Frequency Drive

A Variable Frequency Drive (VFD) modulates compressor speed in response to load and evaporator/condenser pressure. When minimum speed is reached, moveable inlet guide vanes redirect the gas flow into the impeller. VFD's have the following benefits:

- Reduced annual energy costs when there are long periods of part load operation and/or low compressor lift (lower condenser water temperature)
- Reduced motor starting inrush current
- Reduced size of backup generators used to provide emergency power to chillers used on mission critical applications
- Increased power factor to reduce utility surcharges

### Low Operating Costs

Model WME offers world-class full and part load efficiency due to its advanced permanent magnet motor and magnetic bearing VFD compressor design. This allows for significant energy savings at off-design conditions compared to fixed-speed chillers.

## The Control Technology

It is only fitting that this revolutionary chiller design be matched with the advanced control technology to provide the ultimate chiller performance. Our control design includes many unique energy-saving features and interface enhancements.

### MicroTech® Controller

The model WME chiller utilizes MicroTech® digital control electronics to proactively manage unit operation and provide control of external chilled water and cooling tower pumps. The compressor runs at the minimum speed necessary to maintain cooling capacity and lift (which decreases with lower condenser water temperatures), thus minimizing energy usage over the entire range of operating conditions. By constantly monitoring chiller status and real time data, the MicroTech® controller will automatically take proactive measures to relieve abnormal conditions or shut the unit down if a fault occurs.

The WME chiller includes a regenerative power system that is used to provide power to the controls and bearings during a power loss event. When power is lost, the system extracts energy from the spinning motor. The power extracted from the rotor is fed back into the controls and bearings. As the power is extracted from the rotor, the shaft naturally slows down. Once the rotor is exhausted of its kinetic energy, and the shaft has reached a near zero speed, it gently touches down onto the backup bearings. The backup bearings maintain shaft position when the compressor is in an idle state and serve as a failsafe for the primary magnetic bearing system.

Additional smart features that optimize operating efficiency have been incorporated into our MicroTech® controls:

- Cooling tower control including on/off, staging, and VFD
- Direct control of water pumps
- Chilled water rest
- Demand limit control

### HMI Touch Screen

Operation simplicity was one of the main considerations in the development of the MicroTech® control system. The operator interface is a color touch-screen monitor that is mounted on an adjustable arm. Key operating parameters and setpoints are easily accessible. For added convenience, the unit Operating and Maintenance Manual is also viewable on the touch-screen panel.

In order to track chiller performance, the MicroTech® controller can record and plot water temperatures, refrigerant pressures, and motor load. These values can be downloaded through a convenient USB port in the interface and exported into a spreadsheet for further evaluation and recording purposes. The trend history screen is shown in Figure 2.

**Figure 2: HMI Trend History Screen**

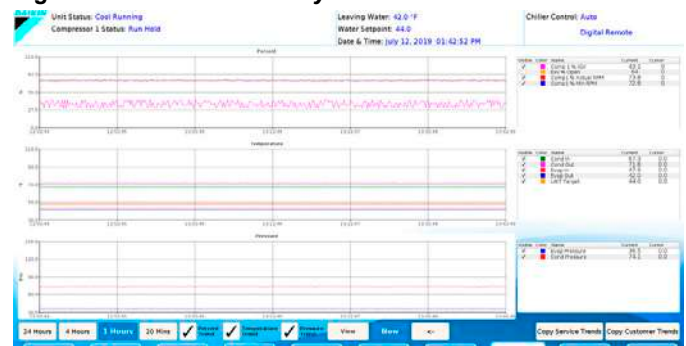

The controller memory (no batteries required) also retains the fault history for troubleshooting and monitoring unit performance. A time/date stamp is associated with each fault. The fault history can be downloaded through the USB port.

### Open Choices™ BAS Flexibility

The exclusive Open Choices™ feature provides seamless integration and comprehensive monitoring, control, and two-way data exchange using industry standard protocols such as LonTalk®, BACnet® or Modbus®. Open Choices™ offers simple and inexpensive flexibility to use the Building Automation System of your choice without an expensive gateway panel. Open Choices™ benefits include:

- Easy to integrate into your BAS of choice
- Factory- or field-installed communications module
- Integrated control logic for factory options
- Easy-to-use local user interface
- Comprehensive data exchange

**RapidRestore® and RideThrough®**

Mission critical facilities such as data centers and hospitals are demanding stringent capabilities for chillers to restart and reach full load operation quickly in the event of a power loss. With both RapidRestore® and RideThrough® capabilities, model WME chillers are engineered to meet those needs.

**RapidRestore®** – Quickly restores cooling capacity when power is restored after a power failure

- **Compressor Re-Start** – Amount of time required for the chiller to re-start
- **Fast Loading** – Amount of time required for the chiller to reach a certain load condition

**RideThrough®** – The ability to maintain operation during a momentary power loss event. When RideThrough® is enabled and a power loss occurs, the compressor motor maintains rotation and the VFD catches and re-synchronizes with the spinning rotor. This permits the chiller to return to its pre-power loss capacity within seconds of power being restored.

**Table 1: RapidRestore® and RideThrough® Times**

<b>Standard Compressor Re-Start</b>	<b>RapidRestore® Compressor Re-Start</b>	<b>Fast Loading to 80% Load</b>	<b>RideThrough®</b>
60 sec	20 sec after power failure*	75 sec**	17 sec***

\* Requires customer supplied Uninterruptible Power Supply (UPS) to the WME control panel  
 \*\* After compressor re-start time  
 \*\*\* Max power loss duration to maintain operation - condition dependent

**Certifications and Standards**

As with many other Daikin Applied chiller products, the Magnitude® model WME meets all necessary certifications and standards.

**LEED®**

For building owners who wish to pursue Leadership in Energy and Environmental Design (LEED®) Green Building Certification, the performance of the WME may contribute points towards Energy and Atmosphere (EA) Credits.

Points earned for Optimize Energy Performance (formerly EA Credit 1) are awarded based on overall building efficiency. The high efficiency of the WME will contribute to the total points earned for this credit.

Enhanced Refrigerant Management (formerly EA Credit 4) qualification is partially determined by tonnage and refrigerant quantity. Vessel stack and tube count selections will affect the quantity of refrigerant in the chiller.

Consult with your Daikin Applied sales representative for more information.

**AHRI Certification**

Part load performance can be presented in terms of Integrated Part Load Value (IPLV), which is defined by AHRI Standard 550/590. Based on AHRI Standard 550/590, and as shown in Figure 3, a typical chiller can operate up to 99% of the time at off-peak conditions and usually spends most of this time at less than 60% of design capacity.

**Figure 3: IPLV Defined by AHRI Standard 550/590**

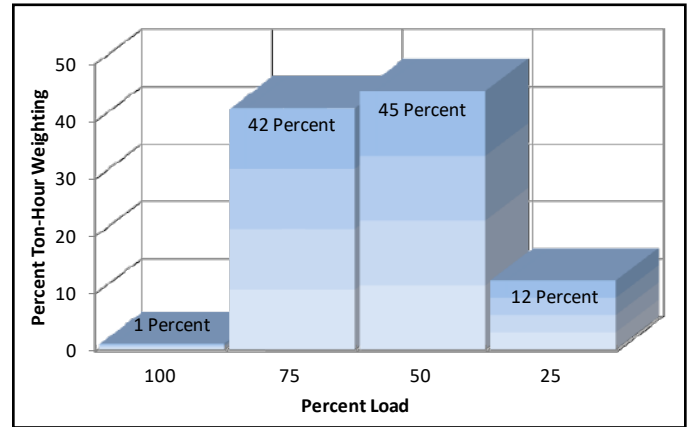

WME chillers are rated and certified to AHRI Standard 550/590. The ability of the WME chillers to achieve very high part load efficiencies, as evidenced by their world-class IPLV ratings, is due primarily to the use of a variable frequency drive and the low friction of the magnetic bearing system. For more information on variable frequency drives, see Integrated Variable Frequency Drive on page 5.

**Compliance with ASHRAE Std. 90.1**

ASHRAE Standard 90.1 was developed to assist owners and designers to make informed choices on a building's design, systems, and equipment selection. Model WME can significantly exceed ASHRAE 90.1 minimum efficiency requirements.

**IBC/OSHPD Seismic Certification**

Daikin Magnitude® WME chillers have been tested and certified by an independent agency, experts in seismic analysis and design to meet IBC seismic and OSHPD preapproval. Find more information about seismic requirements and HVAC systems at [www.DaikinApplied.com](http://www.DaikinApplied.com).

**Factory Testing**

All of centrifugal chillers (50 or 60 hertz) are factory-tested prior to shipment. Operating and safety controls are checked for correct settings and operation. This testing helps reduce field start-up issues and maintain critical construction schedules.

## Unit Dimensions

Figure 4: Representative WME Dimensional Drawing

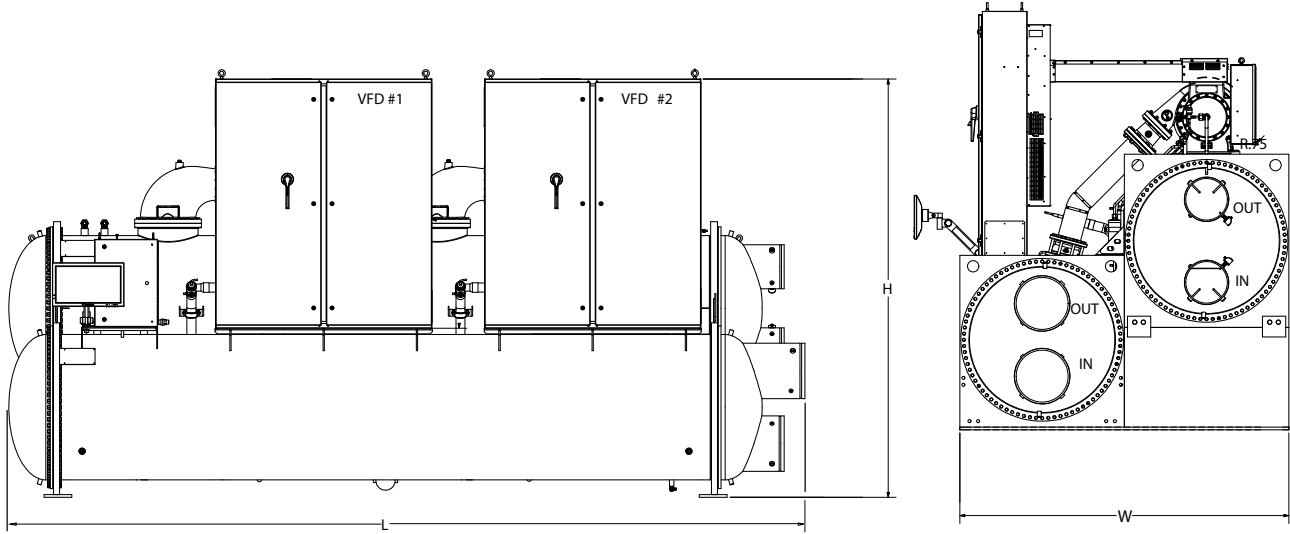

Table 2: WME Overall Dimensions

Model <sup>3</sup>	Heat Exchanger	Dished Waterbox Heads Length <sup>2</sup> in (mm)	Marine Waterbox Heads Length <sup>2</sup> in (mm)	Width in (mm)	Height <sup>1</sup> in (mm)
WME 092*S	E3012 / C2612	170.58 (4332)	188.46 (4787)	55 (1397)	97.69 (2481)
WME 092*S	E3012 / C3012	173.95 (4418)	188.08 (4777)	74.53 (1893)	102.65 (2607)
WME 092*S	E3612 / C3012	175.89 (4467)	194.39 (4937)	82.88 (2105)	
WME 106*S	E3612 / C3012			82.97 (2107)	
WME 106*S	E3612 / C3612	174.64 (4435)	194.64 (4943)	85.13 (2162)	108.74 (2762)
WME092*D	E4216 / C3616	226.06 (5742)	251.21 (6380)	95.87 (2435)	111.24 (2825)
WME092*D	E4216 / C4216			98.03 (2490)	114.82 (2916)
WME099*D	E4216 / C4216				
WME106*D	E4216 / C4216				
WME106*D	E4816 / C4216	231.44 (5878)	256.94 (6526)	104.3 (2649)	117.41 (2982)

- NOTE:**
1. Unit height represents largest configuration possible but does not include height of removable eye bolt.
  2. Unit length represents 2 pass, 150 psi water box configuration with grooved connections.
  3. Unit configuration may be different than illustrated. Refer to certified drawings for specific unit configuration and dimensions.

## Drawing Notes

1. Final connections must allow for 0.5-inch +/- (12.7 mm) manufacturing tolerances.
2. 1.00-inch FPT (25.4 mm) evaporator and condenser relief valves must be piped per ANSI / ASHRAE 15. Number of relief valves could be 1 or 2 on the evaporator and 2 or 4 on the condenser. The number of relief valves is dependent on vessel size.
3. Minimum Clearances (See Figure 5):
  - Check local codes for any additional clearance requirements.
  - Installation layout should be designed by qualified personnel familiar with local codes.
4. 3.25-inch (83 mm) diameter lifting holes are provided. See installation manual (available at [www.DaikinApplied.com](http://www.DaikinApplied.com)) for lifting instructions.
5. Unit shown has standard right-hand water connections. Left-hand connections are available for either vessel. ANSI-flanged nozzle connections are available upon request. When using ANSI-flanged connections add 0.5 inch (13 mm) to each flanged end.
6. Dimensions shown are for units (evaporator / condenser) with standard design pressures. The waterside design pressure is 150 psi (1034 kPa). Consult the factory for unit dimensions with higher design pressures.
7. Unit vibration isolator pads are provided for field installation and when fully loaded are 0.25 inches (6 mm) thick.
8. The shipping skid adds 4.00 inches (105 mm) to the overall unit height.
9. If main power wiring is brought up through the floor, this wiring must be outside the envelope of the unit.
10. The unit is shipped with a full operating charge of refrigerant except with the “Partial Disassembly” knockdown option.
11. Power landing panel is on top of the cabinet; multiple point power will have two separate landing panels as shown in Figure 5.
12. Units with 575V and/or the optional harmonic filter will require additional panels than shown below.

**Figure 5: Minimum Clearances Based on Standard Waterboxes**

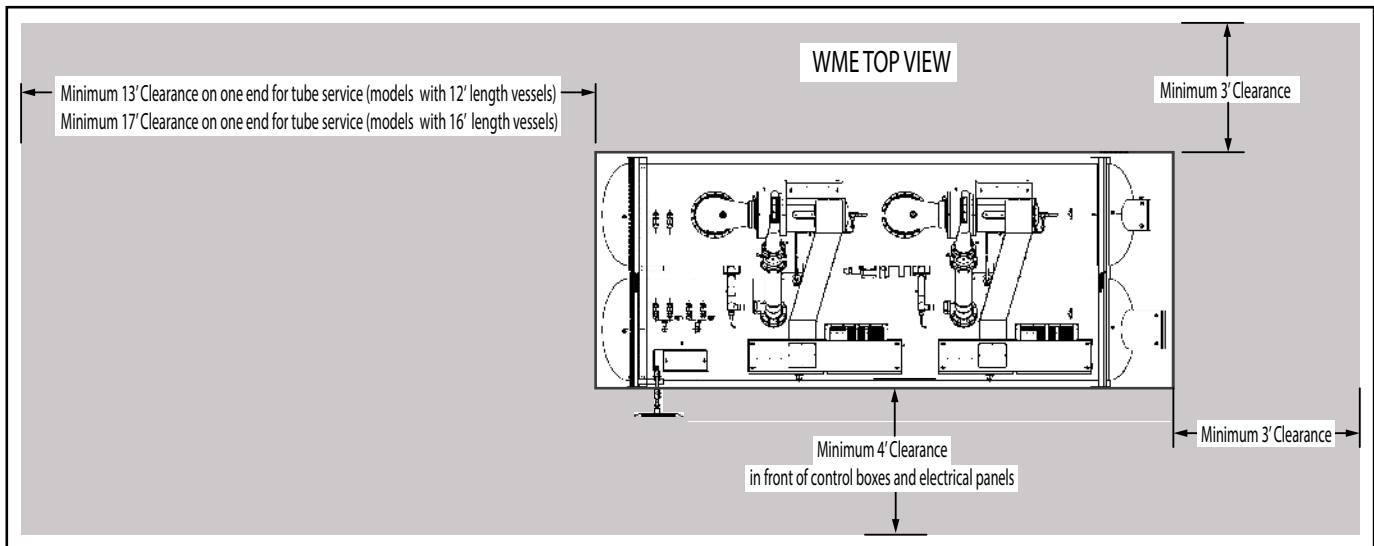

**NOTE:** Hinged type waterboxes may require more clearance. Consult your Daikin Applied sales representative for details.



## Unit Options

### Export Packaging

A wooden skid that aids in moving the unit and tight fitting plastic covering the entire unit to protect it from dirt and grime during transit and storage are standard.

### Pumpout Unit

Pumpout units are available in a variety of sizes with single-phase or three-phase power and with or without storage tanks. Contact your Daikin Applied sales office for details.

### Extended Warranties

Extended 1, 2, 3, or 4 year warranties for parts only or for parts and labor are available for the compressor/motor only, the entire unit, or the entire unit including refrigerant.

### Witness Performance Test

The specified full and/or part load tests, as ordered, are performed in the presence of the customer under the supervision of a factory engineer and include compilation of the test data onto an easy-to-read spreadsheet.

### Non-Witness Test

The specified full and/or part load tests, as ordered, are performed under the supervision of a factory engineer; data is compiled, certified, and transmitted to the customer.

### Refrigerant Charge

Unit ships with a full holding charge of R-134a or R-513A refrigerant as standard. An inert gas holding charge is available as an option.

### Knockdown Shipment

Several options for a knockdown shipment to facilitate unit placement are available. See Retrofit Knockdown on page 15 for details.

## Vessel Options

### Marine Waterboxes

Marine waterboxes that allow the end plate of the waterbox to be removed without disconnecting the water piping from the chiller are optional.

**Figure 6: Marine Waterbox, Flanged Connections**



### Flange Water Connections

A standard unit will have grooved water connections. ANSI raised face flanges on either the evaporator or condenser are optional. Mating flanges must be provided by the field.

### 300 psi Water Side Vessel Construction

150 psi water side vessels are standard. 300 psi water side vessels are optional.

### Epoxy and Ceramic Coating

Evaporator and condenser heads and marine waterboxes can be coated for corrosion protection with either epoxy or ceramic coatings. Tube sheets may also be ceramic coated.

### Single Insulation - Evaporator Shell / Suction Piping

0.75-inch thermal insulation on cold surfaces — excluding heads and waterboxes — is available.

### Single Insulation - Evaporator Heads and Waterboxes

0.75-inch thermal insulation is available.

### Double Insulation - Evaporator Shell / Suction Piping

1.5-inch thermal insulation on cold surfaces — excluding heads and waterboxes — is available.

### Double Insulation - Evaporator Heads and Waterboxes

1.5-inch thermal insulation is available.

### Hinged Waterbox Covers and Heads

Hinges for marine waterbox covers or heads (compact waterboxes) are available to aid in heat exchanger maintenance.

### Tube Size, Wall Thickness and Material

A wide range of tube options are available to accommodate most flow rates and fluids. Standard wall thickness is 0.025-inch. Wall thicknesses of 0.028-inch or 0.035-inch are optional.

## Controls Options

### BAS Interface Module

Factory-installed on the unit controller for the applicable protocol being used (Can also be retrofit):

- BACnet® MS/TP
- BACnet® IP
- BACnet® Ethernet
- LonWORKS®
- Modbus® RTU

## Electrical Options

### Power Panel High and Ultra High Short Circuit Current Rating

Available short circuit current ratings (SCCR) are shown in Table 3.

**Table 3: Short Circuit Current Ratings**

Motor Code	Voltage	Standard Panel SCCR	Optional High SCCR	Optional Ultra High SCCR
M6, M7, 66 and 77	380V - 480V	35 kA* / 50 kA	65 kA	100 kA
	575V	25 kA	35 kA / 50 kA	N/A
68 and 79	380V - 480V	N/A	65 kA	100 kA
	575V	25 kA	35 kA / 50 kA	N/A
M8, M9, 88 and 99	380V - 480V	50 kA	65 kA	100 kA
	575V	25 kA	35 kA	65 kA

**NOTE:** \* 600 amp circuit breaker frame size has a 35 kA SCCR rating. 800 amp circuit breaker frame size has a 50 kA SCCR rating.

### Electro Magnetic Interference (EMI) and Radio Frequency Interference (RFI) Filter

A filter for EMI and RFI is a factory-installed option.

### Harmonic Filter

A factory-provided passive harmonic filter guaranteed to meet the IEEE Standard 519 at an I<sub>sc</sub>/I<sub>L</sub> ratio greater than 20.

### RapidRestore® and RideThrough®

Maintains chiller operation during short power loss events and allows unit to restart and restore capacity quickly if the power event exceeds RideThrough® capabilities. See page 5 for more details.

### Ground Fault Protection

Protects equipment from arcing ground fault damage from line-to-ground fault currents less than those required for conductor protection.

## Special Order Options

The following special order options are available; requiring factory pricing, additional engineering, and possible dimension changes or extended delivery:

1. Non-standard location of nozzle connections on heads (compact waterboxes) or marine waterboxes
2. Clad tube sheets
3. Sacrificial anodes in heads (compact waterboxes) or marine waterboxes
4. Spacer rings on heads to accommodate automatic tube brush cleaning systems (installed by others)
5. Remote-mounted refrigerant monitor, including accessories such as 4-20mA signal, strobe light, audible horn, and air pick-up filter

Figure 7: Refrigeration System Diagram

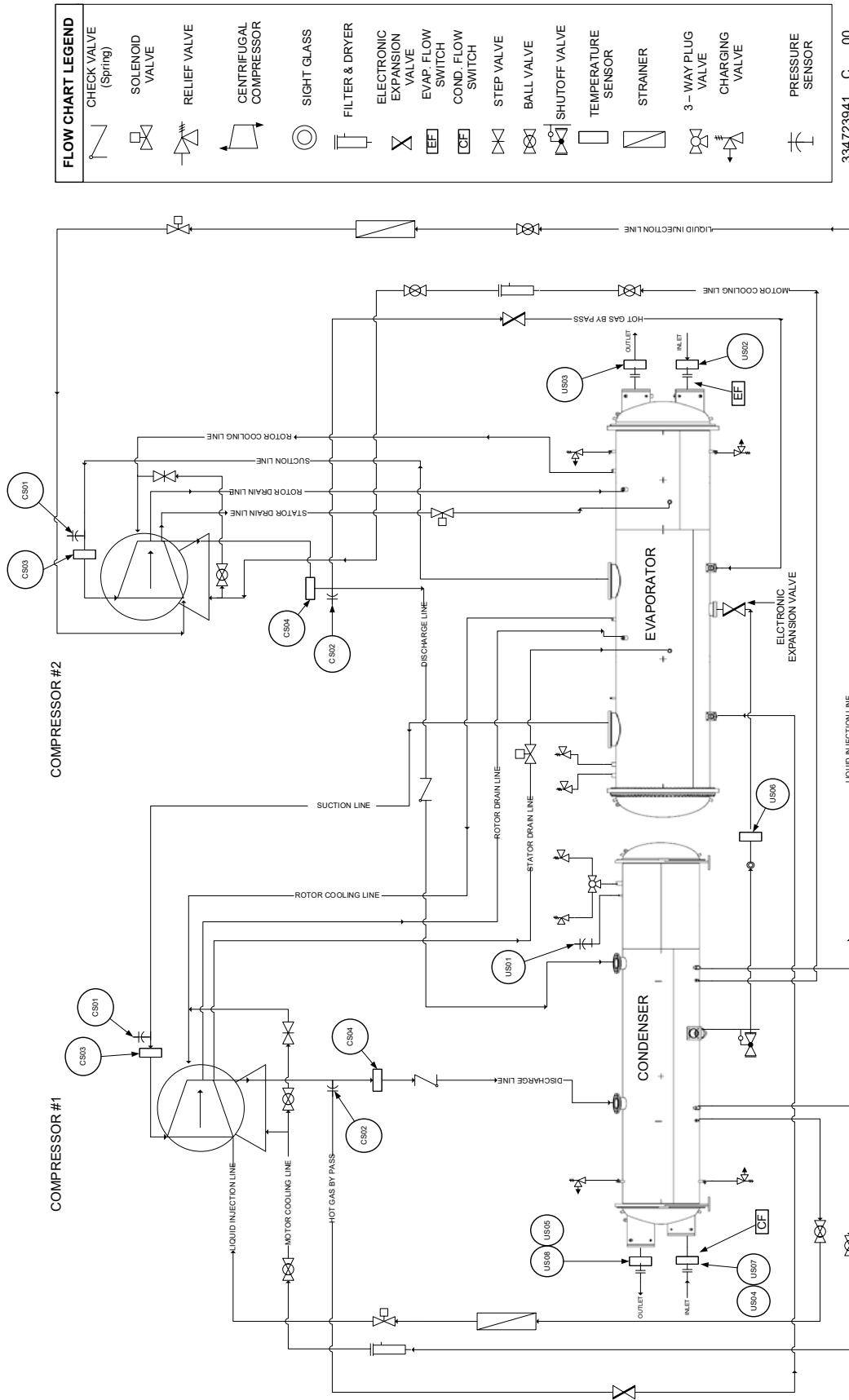

FLOW CHART LEGEND	
	CHECK VALVE (Spring)
	SOLENOID VALVE
	RELIEF VALVE
	CENTRIFUGAL COMPRESSOR
	SIGHT GLASS
	FILTER & DRYER
	ELECTRONIC EXPANSION VALVE
	EVAP. FLOW SWITCH
	COND. FLOW SWITCH
	STEP VALVE
	BALL VALVE
	SHUTOFF VALVE
	TEMPERATURE SENSOR
	STRAINER
	3-WAY PLUG VALVE
	CHARGING VALVE
	PRESSURE SENSOR

334723941 C 00

UNIT CONTROLLER	
BUBBLE NO.	DESCRIPTION
US01	CONDENSER PRESSURE
US02	EVAPORATOR ENTERING WATER TEMPERATURE
US03	EVAPORATOR LEAVING WATER TEMPERATURE
US04	CONDENSER ENTERING WATER TEMPERATURE
US05	CONDENSER LEAVING WATER TEMPERATURE
US06	LIQUID LINE TEMPERATURE

COMPRESSOR CONTROLLER	
BUBBLE NO.	DESCRIPTION
CS01	EVAPORATOR PRESSURE
CS02	DISCHARGE PRESSURE
CS03	COMPRESSOR SUCTION TEMPERATURE
CS04	COMPRESSOR DISCHARGE TEMPERATURE

NOTE: Dual compressor unit shown as a reference.

## Location Requirements

Daikin WME units are designed only for indoor, weather-protected, non-freezing areas consistent with the NEMA 1 rating on the chiller, controls, and electrical panels. Equipment room temperature for operating and standby conditions is 40°F to 104°F (4.4°C to 40°C).

## Vibration Mounting

The Magnitude® WME chiller is almost vibration-free. Consequently, floor mounted spring isolators are not usually required. Neoprene mounting pads are shipped with each unit. It is recommended to continue to use flexible piping connectors to reduce sound transmitted into the pipe and to allow for expansion and contraction.

## System Design

### Water Piping

Field installed water piping to the chiller **must** include:

- air vents at the high points.
- a cleanable water strainer upstream of the evaporator and condenser inlet connections.
- a flow proving device for both the evaporator and condenser to prevent freeze up. Flow switches, thermal dispersion switches, or Delta-P switches can be used. Note that flow switches are factory installed. Additional flow switches can be used only if they are connected in series with the ones already provided.
- sufficient shutoff valves to allow vessel isolation. The chiller must be capable of draining the water from the evaporator or condenser without draining the complete system.

It is **recommended** that field installed water piping to the chiller include:

- temperature sensors at the inlet and outlet connections of both vessels.
- water pressure gauge connection taps and gauges at the inlet and outlet connections of both vessels for measuring water pressure drop.

Piping must be supported to eliminate weight and strain on the fittings and connections. All evaporators and condensers have OGS-type grooved water connections (adhering to Standard AWWA C606) or optional flange connections. The installing contractor must provide matching mechanical connections. Chilled water piping must be adequately insulated.

**NOTE:** This product, in its standard configuration, is equipped with a shell and tube evaporator with carbon steel shell and copper tubes. The water or other fluid used in contact with the wetted surfaces of the heat exchangers must be clean and non-corrosive to the standard materials of construction. Daikin

Applied makes no warranty as to the compatibility of fluids and materials. Non-compatible fluids may void the equipment warranty. If the compatibility of the fluid with the standard materials of construction is in question, a professional corrosion consultant should administer the proper testing and evaluate compatibility.

### Variable Fluid Flow Rates and Tube Velocities

Many chiller system control and energy optimization strategies require significant changes in evaporator water flow rates. The Magnitude® chiller line is well suited to take full advantage of these energy saving opportunities using different combinations of shell sizes, number of tubes, and pass arrangements.

Both excessively high and excessively low fluid flow rates should be avoided. Excessively high fluid flow rates and correspondingly high tube velocities will result in high fluid pressure drops, high pumping power, and potential tube erosion or corrosion damage. Excessively low fluid flow rates and correspondingly low velocities should also be avoided as they will result in poor heat transfer, high compressor power, sedimentation and tube fouling.

### Water Volume

All chilled water systems need adequate time to recognize a load change to avoid short cycling of the compressors or loss of control. The potential for short cycling usually exists when the building load falls below the minimum chiller plant capacity or on close-coupled systems with very small water volumes.

Some of the things the designer should consider when looking at water volume are the minimum cooling load, the minimum chiller plant capacity during the low load period and the desired cycle time for the compressors.

Assuming that there are no sudden load changes and that the chiller plant has reasonable turndown, a rule of thumb of “gallons of water volume equal to two to three times the chilled water gpm flow rate” is often used.

A properly designed storage tank should be added if the system components do not provide sufficient water volume.

## Optimizing Efficiency

A key to improving energy efficiency for any chiller is minimizing the compressor pressure lift. Reducing the lift reduces the compressor work and its energy consumption per unit of output.

The optimum plant design must take into account all of the interactions between chiller, pumps, and tower. The Daikin Energy Analyzer™ II program is an excellent tool to investigate the entire system efficiency, quickly and accurately. It is especially good at comparing different system types and operating parameters. Contact your local Daikin Applied sales office for assistance on your particular application.

## Evaporator

### Reducing Evaporator Fluid Flow

Several popular chiller plant control practices — including Variable Primary Flow systems — advocate reducing the evaporator fluid flow rate as the chiller capacity is reduced. This practice can significantly reduce the evaporator pumping power while having little effect on chiller energy consumption. The Magnitude® WME chillers— with their wide range of shell, tube, and pass combinations— are ideal for application in variable evaporator flow systems as long as the minimum and maximum tube velocities are taken into consideration when selecting the chiller.

If it is decided to vary the evaporator water flow rate, the rate of change should not exceed the minimum or maximum velocity limits. Additionally, the rate of change should not exceed 50% per minute.

### Evaporator Entering Water Temperature

The maximum temperature of water entering the chiller on standby must not exceed 115°F (46.1°C) for R-134a and 112°F (44.4°C) for R-513A. Maximum temperature entering on startup must not exceed 85°F (29.4°C) for R-134a and 80°F (26.6°C) for R-513A.

### Evaporator Leaving Water Temperature

Warmer leaving chilled water temperatures will raise the compressor's suction pressure and decrease the lift, improving efficiency. Using 45°F (7°C) leaving water instead of the typical 42°F (5.5°C) will significantly reduce chiller energy consumption.

### Evaporator Water Temperature Difference

The industry standard has been a 10°F (5.5°C) temperature drop in the evaporator. Increasing the drop to 12°F or 14°F (6.6°C or 7.7°C) can improve chiller efficiency and reduce pump energy consumption.

## Condenser

### Reducing Condenser Fluid Flow

Several popular chiller plant control practices also advocate reducing the condenser fluid flow rate as the chiller load is reduced. This practice can significantly reduce the condenser pumping power, but it may also have the unintended consequence of significantly increasing compressor power since the leaving condenser water temperature is directly related to compressor lift and power. The higher compressor power will typically be larger than the condenser pumping power reduction and will result in a net increase in chiller plant energy consumption. Therefore, before this strategy is applied for energy saving purposes it should be extensively modeled or used in an adaptive chiller plant control system which will take into account all of the interdependent variables affecting

chiller plant energy. If it is decided to use variable condenser fluid flow, the model WME chiller can operate effectively as long as the minimum and maximum tube velocities are taken into consideration when selecting the chiller.

### Reducing Condenser Entering Water Temperature

As a general rule, a 1°F (0.5°C) drop in condenser entering water temperature will reduce chiller energy consumption by two percent. Cooler water lowers the condensing pressure and reduces compressor work. One or two degrees can make a noticeable difference. The incremental cost of a larger tower can be small and provide a good return on investment.

When the ambient wet bulb temperature is lower than design, the entering condenser water temperature of Magnitude® WME chillers can be lowered to improve chiller performance.

Magnitude® WME chillers can start and run with entering condenser water temperatures as low as 40°F (4.4°C). The WME chillers can also start and maintain operation with inverted conditions, meaning the entering condenser water temperature can be lower than the leaving chilled water temperature. Contact your local Daikin Applied sales office if your application requires a condenser entering water temperature lower than 40°F (4.4°C).

Depending on local climatic conditions, using the lowest possible entering condenser water temperature may be more costly in total system power consumed than the expected savings in chiller power would suggest, due to the excessive fan power required. The trade-off between better chiller efficiency and fan power should be analyzed for best overall system efficiency. The Energy Analyzer™ II program (available from your Daikin Applied sales representative) can optimize the chiller/tower operation for specific buildings in specific locales.

### Condenser Water Temperature Difference

The industry standard of 3 gpm/ton or about a 9.5°F (5.3°C) delta-T works well for most applications.

### Condenser Water Temperature Control

Condenser water control is an important consideration in chiller plant design since condenser water temperature will directly impact chiller operation and efficiency. When the ambient wet bulb temperature is lower than peak design, the entering condenser water temperature from the cooling tower can be allowed to fall, improving chiller performance. However, operational issues may occur when the condenser water temperatures are either too high or too low. The WME chiller provides several options to assist the chiller plant designer in providing the optimum control of condenser water temperature.

#### Cooling Tower Control

Control of the cooling tower is required to maintain stability and avoid operational issues. This can be achieved through

a BAS or by using the MicroTech® controller. For systems utilizing a common condenser water loop for multiple purposes, the BAS contractor must provide the control but use of the MicroTech® output signal is still recommended.

The preferred cooling tower control utilizes a variable speed fan. MicroTech® will provide a control signal to determine the proper fan speed. It can also control up to three stages of fan cycling. Note that fan cycling can cause cooling tower water temperature to fluctuate as fans stage on/off, potentially adding instability to the system.

Special consideration must be given to starting the chiller when cold condenser water is present, such as with inverted starts or changeover from free (tower) cooling to mechanical cooling. It is required that some method be used to control the condenser water to maintain proper head pressure as indicated by the MicroTech® controller.

Acceptable methods are outlined below and each of these options can be controlled by the MicroTech® or through a BAS utilizing the MicroTech® output signals.

1. Three-Way Bypass Valve Operation

A traditional method for building condenser pressure at startup with colder condenser water is with the use of a three-way bypass valve. The device blends warmer water leaving the condenser with cooler water from the cooling tower at the condenser inlet. The bypass valve position will change until full flow from the tower to the condenser is obtained. The MicroTech® provides only the valve position control signal. Main power to drive the valve's actuator must be provided by the installer. The three-way valve should be located close to the chiller within the equipment room to minimize the volume of water.

2. Two-Way Valve Operation

Another condenser control method is to use a modulating two-way control valve located on the outlet connection of the condenser. The valve will be nearly closed at startup to restrict water flow, which keeps generated heat in the condenser until an acceptable minimum condenser pressure is reached. As heat builds, the valve will open slowly until a full flow condition from the cooling tower is established. A separate power source is required to provide power to the valve actuator.

3. VFD Operating with a Condenser Water Pump

A third method of condenser control for startup is utilizing a variable frequency drive with the condenser water pump. The speed will change as directed by the MicroTech® output signal until design flow is reached. Speed adjustments may be required during the initial chiller startup as determined by the service technician.

**NOTE:** Not using the MicroTech® logic to control valves and variable frequency drives may result in system

instability, capacity reduction, and issues starting the chiller with cold condenser water temperature.

Condenser Pump Sequencing

It is recommended to utilize the logic built into the MicroTech® controller to start the condenser pump. MicroTech® has the capability to operate a primary pump and a secondary standby pump. The condenser water flow should be stopped when the chiller shuts off. This will conserve energy and prevent refrigerant from migrating to the condenser.

Water Side Economizer Cycle Operation

Water side economizers are commonly used for ASHRAE 90.1 compliance and energy savings. This system utilizes a heat exchanger external to the chiller when cold cooling tower water is available to provide cooling. The most common system has a heat exchanger used in conjunction with the chiller's evaporator.

The BAS contractor will need to provide controls for the heat exchanger including isolation valves and temperature control. The BAS contractor will also need to control the isolation valves for the chiller. It is important to use slow-acting type valves to prevent rapid changes in system flows. Changeover from economizer cooling to mechanical cooling requires one of the methods previously mentioned to maintain suitable condenser head pressure.

Contact your local Daikin Applied representative for more information on this application.

## Retrofit Knockdown

It is estimated that fifty percent of retrofit applications require partial or complete disassembly of the chiller. Magnitude® WME chillers are relatively easy to disassemble due to the small compressor size, simplified refrigerant piping, and the absence of a lubrication system with its attendant components and piping. Various knockdown arrangements are available as options.

### Type A Knockdown - “Bolt-Together Construction”

Chillers are built and shipped completely assembled with bolt-together construction on major components for field disassembly and re-assembly on the job site. “Bolt-Together Construction” applies to the following:

**Figure 8: “Bolt-Together Construction” - Representative Illustration**

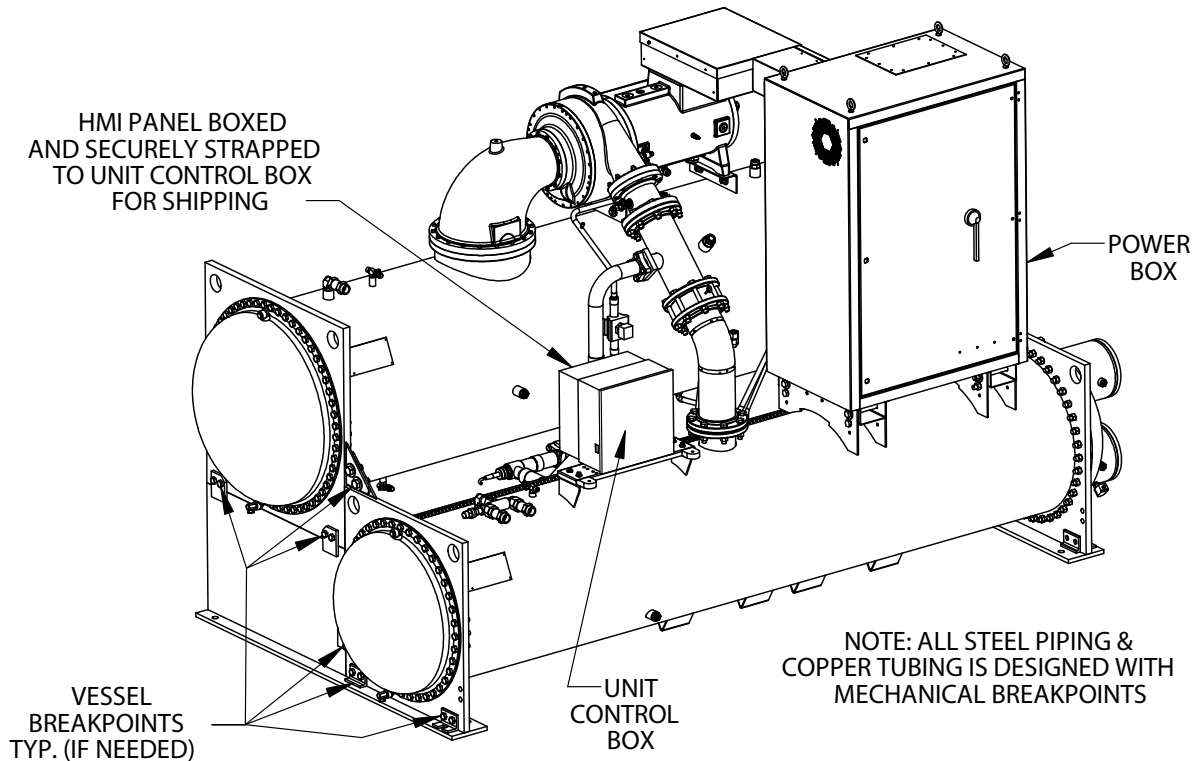

### Scope:

- Unit ships completely assembled to the jobsite.
- Bolt-together construction allows for site disassembly based on required clearances at each jobsite.
- Unit ships with full factory refrigerant charge in the chiller.
- Suction and discharge lines have bolt-on flanges.
- Unit ships with vessel and/or head insulation, if ordered.
- Site disassembly and re-assembly must be supervised or completed by Daikin Applied service personnel.
- Ideal for retrofit applications.

**Type B Knockdown - “Partial Disassembly”**

Compressor(s), power boxes, and control boxes are removed and shipped on separate skids; combined vessel stack is shipped together as a sub-assembly. “Partial Disassembly” applies to the following:

**Figure 9: “Partial Disassembly” - Representative Illustration**

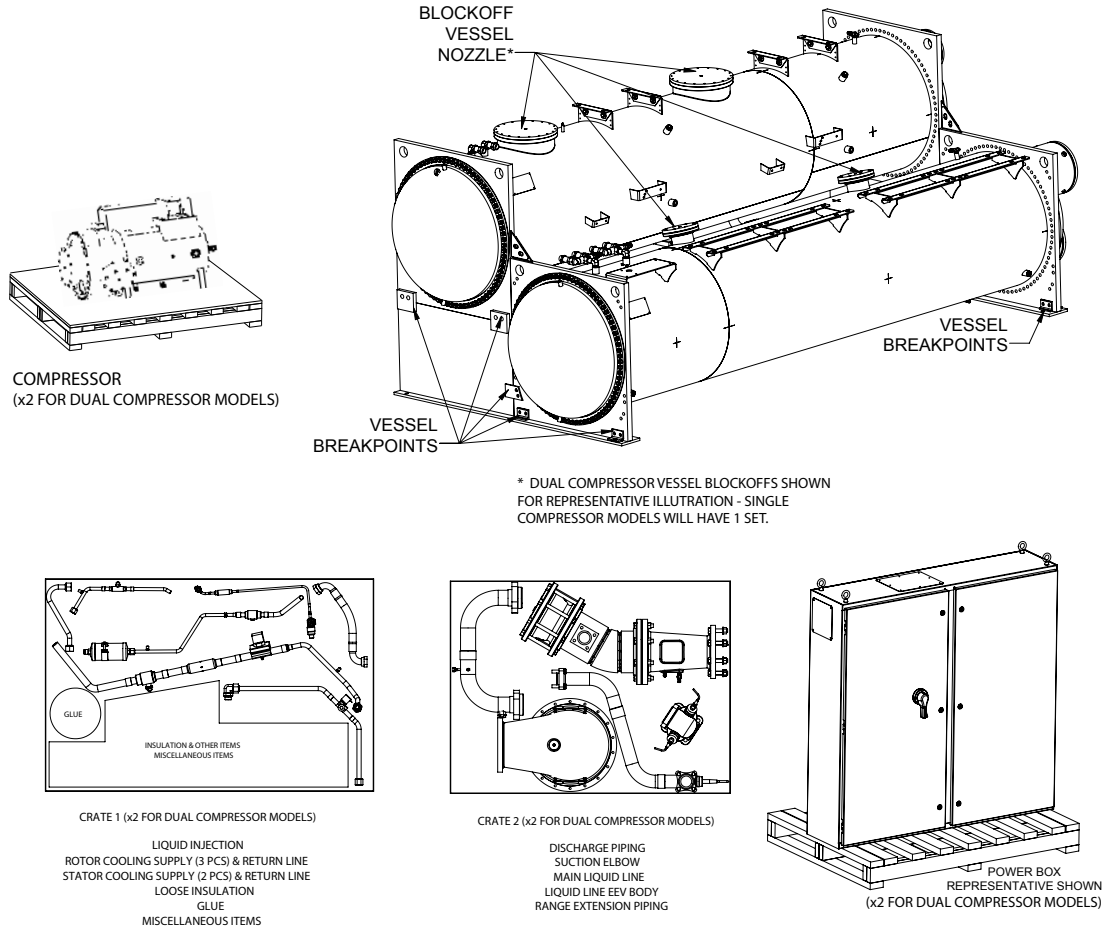

**Scope:**

- All associated piping and wiring remain attached, if possible.
- Compressors and vessels receive an inert gas holding charge.
- All free piping ends are capped.
- Suction and discharge lines have bolt-on flanges and, if possible, remain attached.
- Unit ships with vessel and/or head insulation, if ordered.
- Refrigerant will not be shipped with the chiller and must be procured locally.
- Site re-assembly must be supervised or completed by Daikin Applied service personnel.
- Ideal for retrofit applications where installation access is narrow or restricted and where refrigerant may be secured locally.



# Magnitude® Magnetic Bearing Centrifugal Chillers

## PART 1 - GENERAL

### 1.1 SUMMARY

- A. Section includes design, performance criteria, refrigerants, controls, and installation requirements for water-cooled centrifugal chillers.

### 1.2 REFERENCES

- A. Comply with the following codes and standards: AHRI 550/590, AHRI 575, NEC, ANSI/ASHRAE 15, OSHA as adopted by the State, ETL, ASME Section VIII

### 1.3 SUBMITTALS

- A. Submittals shall include the following:
  1. Dimensioned plan and elevation view, including required clearances, and location of all field piping and electrical connections.
  2. Summaries of all auxiliary utility requirements such as: electricity, water, air, etc. Summary shall indicate quality and quantity of each required utility.
  3. Diagram of control system indicating points for field interface and field connection. Diagram shall fully depict field and factory wiring.
  4. Manufacturer's certified performance data at full load plus IPLV or NPLV.
  5. Installation and Operating Manuals.

### 1.4 QUALITY ASSURANCE

- A. Regulatory Requirements: Comply with the codes and standards in Section 1.2.
- B. Chiller manufacturer plant shall be ISO 9001 and ISO 14001 Certified.
- C. The chiller shall be factory tested at the manufacturer's plant prior to shipment on an AHRI approved test stand.

### 1.5 DELIVERY AND HANDLING

- A. Chillers shall be delivered to the job site completely assembled and charged with refrigerant R-134a or R-513A refrigerant and be shipped with a weather resistant cover.  
-- OR --
- A. [For Type A Knockdowns] The unit shall be delivered to the job site completely assembled and charged with refrigerant and ready for field knockdown. Contractor shall leak test, recover refrigerant, evacuate, and charge with refrigerant after reassembly.  
-- OR --

- A. [For Type B Knockdowns] The compressor, suction and discharge piping, VFD power panel and touch screen shall be removed and shipped separately. All wiring and piping shall remain attached where possible. The remaining loose parts shall be packaged in a separate crate. The unit is to be factory tested and shipped with an inert gas holding charge, evaporator insulated and a kit for compressor insulation. Contractor shall leak test, evacuate and charge with refrigerant after reassembly.
- B. Comply with the manufacturer's instructions for rigging and transporting units. Leave protective covers in place until installation.

### 1.6 WARRANTY

- A. The chiller manufacturer's warranty shall cover parts and labor costs for the repair or replacement of defects in material or workmanship for a period of one year from equipment startup or 18 months from shipment, whichever occurs first [OPTION] and also include an additional extended warranty for one -OR- two- OR three -OR- four years on the entire unit -OR- on entire unit including refrigerant coverage -OR- compressor only.

### 1.7 MAINTENANCE

- A. Maintenance of the chillers in accordance with manufacturer's recommendations as published in the installation and maintenance manuals shall be the responsibility of the owner.

## PART 2 - PRODUCTS

### 2.1 ACCEPTABLE MANUFACTURERS

- A. Basis of Design - Daikin Magnitude® model WME, including the standard product features and all special features required per the plans and specifications.
- B. Equal Products - Equipment manufactured by [ENTER MANUFACTURER NAME HERE] may be acceptable as an equal. Naming these products as equal does not imply that their standard construction or configuration is acceptable or meets the specifications. Equipment proposed "as equal" must meet the specifications including all architectural, mechanical, electrical, and structural details, all scheduled performance and the job design, plans and specifications.

### 2.2 UNIT DESCRIPTION

- A. Provide and install as shown on the plans a factory assembled, charged, and tested water-cooled packaged

centrifugal chiller. Chillers shall have no more than two oil-free, magnetic bearing, semi-hermetic centrifugal compressors (no exceptions). Each compressor shall have an integrated variable-frequency drive operating in concert with inlet guide vanes for optimized full and part load efficiency. On two-compressor units, the evaporator and condenser refrigerant sides and the expansion valve shall be common and the chiller shall be capable of running on one compressor with the other compressor or any of its auxiliaries inoperable or removed.

### 2.3 DESIGN REQUIREMENTS

- A. General: Provide a complete water-cooled, semi-hermetic oil-free centrifugal compressor water chiller as specified herein. The unit shall be provided according to standards indicated in Section 1.2. In general, unit shall consist of one or two magnetic bearing, completely oil-free centrifugal compressors, refrigerant, condenser and evaporator, and control systems including integrated variable frequency drive, operating controls and equipment protection controls. Chillers shall be charged with R-134a or R-513A refrigerant. If a manufacturer offers a chiller using any HCFC refrigerant, the manufacturer shall provide, in writing, documentation signed by an officer of the company assuring refrigerant availability and price schedule for a 20-year period.
- B. The entire chiller system, including all pressure vessels, shall remain above atmospheric pressure during all operating conditions and during shut down to ensure that non-condensables and moisture do not contaminate the refrigerant and chiller system. If any portion of the chiller system is below atmospheric pressure during either operation or shut down, the manufacturer shall include, at no charge:
  - 1. A complete purge system capable of removing non-condensables and moisture during operation and shut-down.
  - 2. A 20-year purge maintenance agreement that provides parts, labor, and all preventative maintenance required by the manufacturer's operating and maintenance instructions.
  - 3. The manufacturer shall also include at no charge for a period of 20 years an annual refrigerant analysis report to identify chiller contamination due to vacuum leaks. If the analysis identifies water, acid, or other contaminant levels higher than specified by the manufacturer, the refrigerant must be replaced or returned to the manufacturer's original specification at no cost to the owner.
  - 4. The manufacturer shall include a factory-installed and wired system that will enable service personnel to

readily elevate the vessel pressure during shutdown to facilitate leak testing.

- C. Performance: Refer to chiller performance rating.
- D. Acoustics: Sound pressure for the unit shall not exceed the following specified levels. Provide the necessary acoustic treatment to chiller as required. Sound data shall be measured in dB according to AHRI Standard 575 and shall include overall dBA. Data shall be the highest levels recorded at all load points.

Octave Band								Overall dBA
63	125	250	500	1000	2000	4000	8000	

### 2.4 CHILLER COMPONENTS

- A. Compressors:
  - 1. The unit shall utilize magnetic bearing, oil-free, semi-hermetic centrifugal compressors. The compressor drive train shall be capable of coming to a controlled, safe stop in the event of a power failure.
  - 2. The motor shall be of the semi-hermetic type, of sufficient size to efficiently fulfill compressor horsepower requirements. It shall be liquid refrigerant cooled with internal thermal sensing devices in the stator windings. The motor shall be designed for variable frequency drive operation.
    - a. If the compressor design requires a shaft seal to contain the refrigerant, the manufacturer shall supply a 20 year parts and labor warranty on the shaft seal and a lifetime refrigerant replacement warranty if a seal failure leads to refrigerant loss, or the chiller manufacturer shall assume all costs to supply and install a self contained air conditioning system in the mechanical space sized to handle the maximum heat output of the open drive motor. The energy required to operate this air conditioning system shall be added to the chiller power at all rating points for energy evaluation purposes.
    - b. If the compressor/motor uses any form of antifriction bearing (roller, ball, etc), the chiller manufacturer shall provide the following at no additional charge:
      - A 20-year bearing warranty and all preventative maintenance as specified by the manufacturer's published maintenance instructions.
      - At start up, a three-axis vibration analysis and written report to establish bearing condition baseline.
      - An annual three-axis vibration analysis and

written report indicating bearing condition.

3. The chiller shall be equipped with an air or refrigerant cooled integrated Variable Frequency Drive (VFD) to automatically regulate compressor speed in response to cooling load and the compressor pressure lift requirement. Liquid cooling is unacceptable. If a condenser water-cooled VFD is supplied, the manufacturer shall supply factory installed dual water filters with a bypass valve and pressure differential switch factory wired to the chiller control panel to indicate that a filter has clogged and requires service. The pressure differential switch shall also provide a separate dry contact which can be connected to the BAS system as a means of notifying operating personnel of the need to service the filters. If the condenser cooling circuit includes an intermediate heat exchanger, it must be of the brush cleanable shell and tube style. Brazed plate heat exchangers which cannot be field cleaned are not acceptable. Movable inlet guide vanes and variable compressor speed shall provide unloading. The chiller controls shall coordinate compressor speed and guide vane position to optimize chiller efficiency.

4. [OPTIONAL] Harmonic Filter

The chiller shall be equipped with a factory-mounted and wired passive harmonic filter guaranteed to meet the IEEE Standard 519 at an Isc/IL ratio greater than 20.

- OR -

The chiller shall be supplied with a 575V passive harmonic filter shipped loose for field-mounting and wiring. It shall be guaranteed to meet the IEEE Standard 519 at an Isc/IL ratio greater than 20.

B. Evaporator and Condenser:

1. The evaporator and condenser shall be separate vessels of the shell-and-tube type, designed, constructed, tested and stamped according to the requirements of the ASME Code, Section VIII. The tubes shall be individually replaceable and secured to the intermediate supports without rolling. The evaporator shall be flooded type with [0.025 in.] –OR– [0.028 in.] –OR– [0.035 in.] wall [copper] –OR– [90/10 CuNi] tubes rolled into [carbon steel] –OR– [ceramic-coated steel] tubesheets. The water side shall be designed for a minimum of [150 psig] –OR– [300 psig]. The heads shall be [carbon steel] –OR– [epoxy-coated steel] –OR– [Monel-clad] –OR– [Stainless Steel]. Water connections shall be grooved suitable for [grooved couplings] –OR– [flanged connections]. The evaporator shall have [dished heads with valved drain and vent connections] –OR– [shall be equipped with marine waterboxes with removable covers and vent and drain connections]. The evaporator shall

have [right-hand] –OR– [left-hand] connections when looking at the unit control panel.

[OPTIONAL] Waterbox heads shall be hinged on both ends.

2. The condenser shall have [0.025 in.] –OR– [0.028 in.] –OR– [0.035 in.] wall [copper] –OR– [90/10 CuNi] –OR– [70/30 CuNi] –OR– [stainless steel] –OR– [titanium] tubes rolled into [carbon steel] –OR– [Monel-clad] –OR– [stainless steel clad] –OR– [titanium-clad] –OR– [ceramic-coated] tube sheets. Water connections shall be [grooved suitable for grooved couplings] –OR– [flanged]. The water side shall be designed for a minimum of [150 psig] –OR– [300 psig]. The condenser shall have [dished heads with valved drain and vent connections] –OR– [shall be equipped with marine waterboxes with removable covers and vent and drain connections]. The condenser shall have [right-hand] –OR– [left-hand] connections when looking at the unit control panel.

[OPTIONAL] Waterbox heads shall be hinged on both ends.

3. Provide sufficient isolation valves and condenser volume to hold the full unit refrigerant charge in the condenser during servicing or provide a separate pumpout system and storage tank sufficient to hold the charge of the largest unit being furnished.
4. An electronic expansion valve shall control refrigerant flow to the evaporator. Fixed orifice devices or float controls with hot gas bypass are not acceptable because of inefficient control at low load conditions. The liquid line shall have moisture indicating sight glass.
5. Re-seating type spring loaded pressure relief valves according to ASHRAE-15 safety code shall be furnished. The evaporator shall be provided with single or multiple valves. The condenser shall be provided with dual relief valves equipped with a transfer valve so one relief valve can be removed for testing or replacement without loss of refrigerant or removal of refrigerant from the condenser. Rupture disks are not acceptable.
6. [OPTIONAL] The evaporator shall be insulated with [3/4 in.] OR [1.5 in.] thick CFC and HCFC-free closed-cell flexible elastomeric foam insulation material with 100% adhesive coverage. The insulation shall have an additional outer protective layer of 3mm thick PE embossed film to provide superior damage resistance. Insulation without the protective outer film shall not be acceptable. UV resistance level shall meet or exceed a rating of 'Good' in accordance with the UNI ISO 4892 - 2/94 testing method.

7. [OPTIONAL] The evaporator waterbox shall be insulated with UL recognized [3/4 in.] OR [1 ½ in.] closed cell insulation. All joints and seams shall be carefully sealed to form a vapor barrier.
  8. Provide factory-mounted and wired, thermal-dispersion water flow switches on each vessel to prevent unit operation with no or low water flow.
- C. Vibration Isolation
1. Provide neoprene waffle-type vibration isolators for each corner of the unit.
- D. Power Connections
1. Power connection shall be single point to a factory-mounted disconnect switch OR shall be multipoint to each compressor power panel on two-compressor units.
- E. Chiller Control
1. The unit shall have a microprocessor-based control system consisting of a touch-screen operator interface and a unit controller.
  2. The touch-screen shall display the unit operating parameters, accept setpoint changes (multi-level password protected) and be capable of resetting faults and alarms. The following parameters shall be displayed on the home screen and also as trend curves on the trend screen:
    - Entering and leaving chilled and condenser water temperatures
    - Evaporator and condenser saturated refrigerant pressures
    - Percent of 100% speed (per compressor)
    - % of rated load amps for entire unit
  3. In addition to the trended items above, all other important real-time operating parameters shall also be shown on the touch-screen. These items shall be displayed on a chiller graphic showing each component. At a minimum, the following critical areas must be monitored:
    - Compressor actual speed, maximum speed, percent speed
    - Evaporator water in and out temperatures, refrigerant pressure and temperature
    - Condenser water in and out temperatures, refrigerant pressure and temperature
    - Liquid line temperature
    - Chilled water setpoint
    - Compressor and unit state and input and output digital and analog values
  4. A fault history shall be displayed using an easy to decipher, color coded set of messages that are date and time stamped. The alarm history shall be downloadable from the unit's USB port. An operating and maintenance manual specific for the unit shall be viewable on the screen and downloadable.
5. All setpoints shall be viewable and changeable (multi-level password protected) on the touch screen and include setpoint description and range of set values.
  6. Automatic corrective action to reduce unnecessary cycling shall be accomplished through preemptive control of low evaporator or high discharge pressure conditions to keep the unit operating through abnormal transient conditions.
  7. The chiller shall be capable of automatic control of: evaporator and condenser pumps (primary and standby), up to 3 stages of cooling tower fan cycling control and a tower modulating bypass valve or cooling tower fan variable frequency drive.
  8. Optionally, the factory mounted controller(s) shall support operation on a BACnet®, Modbus® or LonWORKS® network via one of the data link / physical layers listed below as specified by the successful Building Automation System (BAS) supplier.
    - Modbus®
    - BACnet® MS/TP master (Clause 9)
    - BACnet® IP, (Annex J)
    - BACnet® ISO 8802-3, (Ethernet)
    - LonTalk® FTT-10A. The unit controller shall be LonMark® certified.
  9. The information communicated between the BAS and the factory mounted unit controllers shall include the reading and writing of data to allow unit monitoring, control and alarm notification as specified in the unit sequence of operation and the unit points list.
  10. For chillers communicating over a LonMark® network, the corresponding LonMark® eXternal Interface File (XIF) shall be provided with the chiller submittal data.
  11. All communication from the chiller unit controller as specified in the points list shall be via standard BACnet® objects. Proprietary BACnet® objects shall not be allowed. BACnet® communications shall conform to the BACnet® protocol (ANSI/ASHRAE135-2001). A BACnet® Protocol Implementation Conformance Statement (PICS) shall be provided along with the unit submittal.
  12. The chiller shall be able to maintain operation during a momentary power loss event lasting up to 5 seconds when operated at standard AHRI load and lift conditions. The chiller shall be able to ride through this momentary power loss event without shutting down. Chillers not able to maintain operation during momentary power loss events lasting up to 5 seconds shall include a properly sized thermal storage tank to maintain temperature stability in the system.

13. The chiller shall be equipped with the capability to restart and reach full load quickly in the event of a power interruption. The compressor shall be capable of restarting in less than 60 seconds after power is restored and shall reach 80% load within 75 seconds. Chillers not able to restart or load within this time frame shall include a properly sized thermal storage tank to maintain temperature stability in the system.

## 2.5. OPTIONAL ITEMS

A. The following optional items shall be furnished:

1. Open OR closed export crate
2. Pumpout unit, with or without storage vessel
3. Refrigerant monitor
4. Non-witness performance test (water only) in accordance with procedures and to the tolerances contained in AHRI Standard 550/590.

-- OR --

Witness performance test (water only) in accordance with procedures and to the tolerances contained in AHRI Standard 550/590.

5. OSHPD Certification: The chiller shall be OSHOD Pre-Approved per OSP-0116-10 and be so labeled. The chiller shall be seismically certified to Short Period Design Spectral Response  ${}^sDS=2.0$  gravities at roof height ( $z/h=1.0$ ) and  ${}^sDS=2.5 @ z/h=0$  (ground). The chiller must be mounted to a rigid base and may use neoprene waffle vibration pads.

-- OR --

IBC Certification: The chiller shall be certified to the following codes and standardss; 2015 IBC, ICC-ES AC-156. The chiller must be mounted to a rigid base and may use neoprene waffle vibration pads.

## PART 3 - EXECUTION

### 3.1 INSTALLATION

A. Installing contractor to:

1. Install per manufacturer's requirements, shop drawings, and contract documents.
2. Adjust chiller alignment on foundations, or subbases as called for on drawings.
3. Arrange piping to allow for dismantling to permit head removal and tube cleaning.
4. Coordinate electrical installation with electrical contractor.
5. Coordinate controls with control contractor.
6. Provide all material required for a fully operational and functional chiller.

### 3.2 START-UP

- A. Factory Start-Up Services: Provide for as long a time as is necessary to ensure proper operation of the unit, but in no case for less than two full working days. During the period of start-up, the start-up technician shall instruct the owner's representative in proper care and operation of the unit.

THIS PAGE INTENTIONALLY LEFT BLANK

THIS PAGE INTENTIONALLY LEFT BLANK



### ***Daikin Applied Training and Development***

Now that you have made an investment in modern, efficient Daikin Applied equipment, its care should be a high priority. For training information on all Daikin Applied HVAC products, please visit us at [www.DaikinApplied.com](http://www.DaikinApplied.com) and click on Training, or call 540-248-9646 and ask for the Training Department.

### ***Warranty***

All Daikin Applied equipment is sold pursuant to its standard terms and conditions of sale, including Limited Product Warranty. Consult your local Daikin Applied representative for warranty details. To find your local Daikin Applied representative, go to [www.DaikinApplied.com](http://www.DaikinApplied.com).

### ***Aftermarket Services***

To find your local parts office, visit [www.DaikinApplied.com](http://www.DaikinApplied.com) or call 800-37PARTS (800-377-2787). To find your local service office, visit [www.DaikinApplied.com](http://www.DaikinApplied.com) or call 800-432-1342.

This document contains the most current product information as of this printing. For the most up-to-date product information, please go to [www.DaikinApplied.com](http://www.DaikinApplied.com).

Products manufactured in an ISO Certified Facility.